

RoboRack Half Rack Cases from Gemstar offer MIL-STD durability and airtight protection for the most sensitive electronic components. Part of our Stronghold® line, these cases feature rotationally-molded double walls and thick corners for rugged, versatile, and dependable protection.

Standard Features

- Rotationally molded, double-walled durability
- Watertight, airtight and dust-proof with automatic pressure relief valve
- Meets or exceeds MIL-STD 810G and meets military LLRC standards*
- Recessed, heavy-duty black stainless steel hardware
- Field serviceable hardware
- Spring-loaded handles
- Tongue & groove construction with gasket
- Interlocking, stackable design
- Fully removable lids that hang on the sides
- Edge wheels and an extendable pull handle
- Guaranteed Performance*

* See website for guarantee details, complete certifications and test procedures.

Standard Models

- SR1212-5U18

Standard and Custom Options

- Offering a robust selection of custom features, colors, and sizes. For more information visit Gemstarmfg.com, or contact your local Distributor or Sales Manager.

Standard Color Options**



** Colors are approximate and are for visual purposes only.



SR1212-5U18 Top Profile

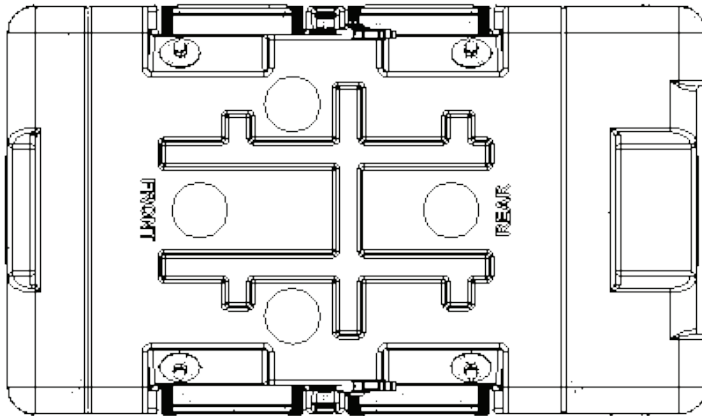

MODEL NUMBER KEY

SR1212-5U18

Height ———— Rack Depth
Width ———— Rack Unit
Model numbers refer to interior dimensions

SR1212-5U18 Side and End Profile

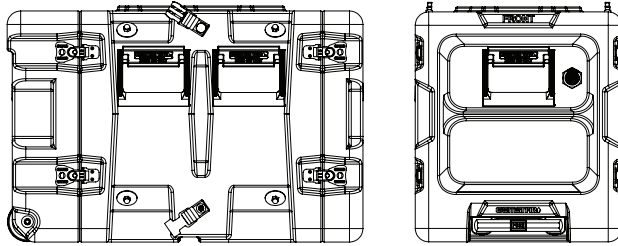

SR1212-5U18 Rack

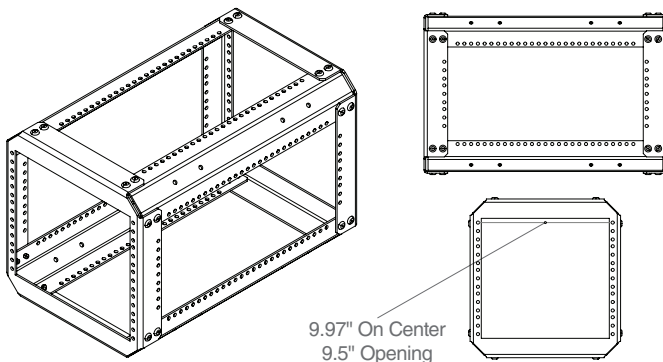

5U Rack

Light weight aluminum rack

Nominal INT Dimension	23.5"L x 12.1"W x 12.5"H 597L x 307W x 318H mm
Front Lid Depth	1.75" 44 mm
Rear Lid Depth	3.75" 95 mm
Nominal EXT Dimension	27"L x 15.4"W x 17.2"H 696L x 391W x 437H
Rack Unit Information	5
Rack EXT Dimensions	18"L x 11.1"W x 11.8"H 457L x 282 W x 300H mm
Rack INT Dimensions	17.7"L x 9.5"W x 8.8"H 450L x 241W x 224H mm
Approx. Weight	34.5 lbs 15.6 kg
Features	<ul style="list-style-type: none"> • Removable lids • Spring-Loaded ABS Handles (SS optional) • PRV