

8 7 6 5 4 3 2 1

D

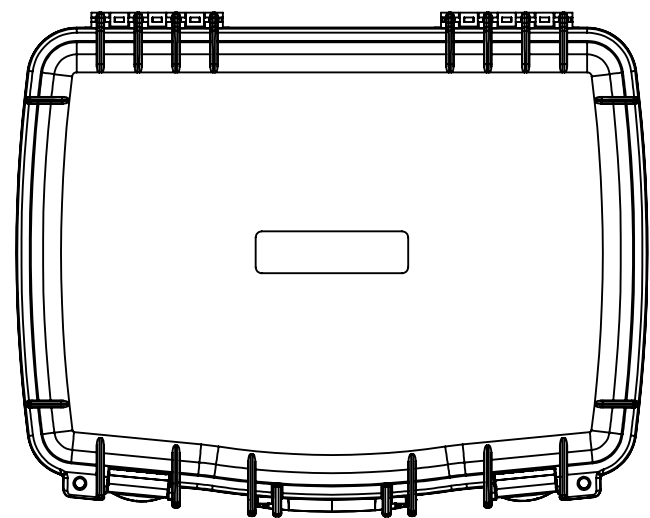

C

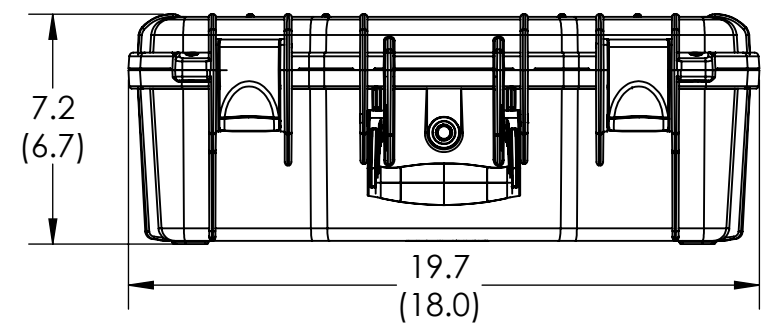

B

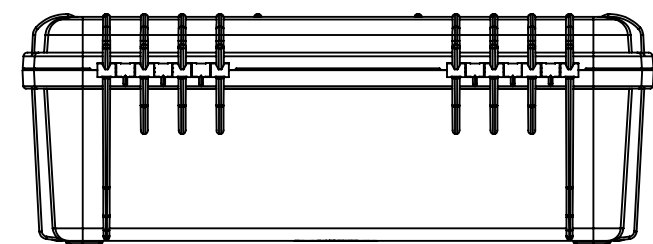
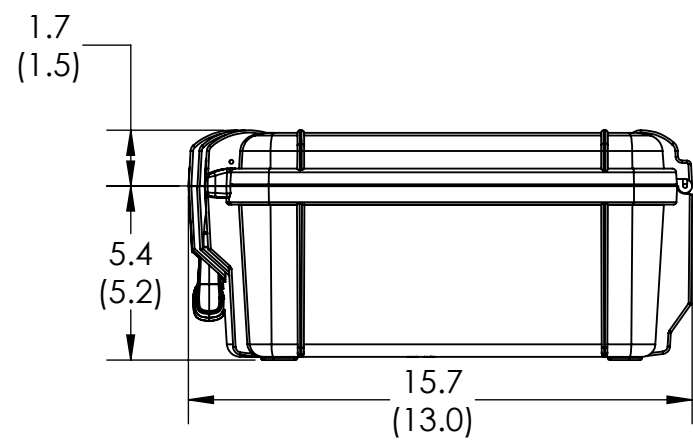

D

C

B

A

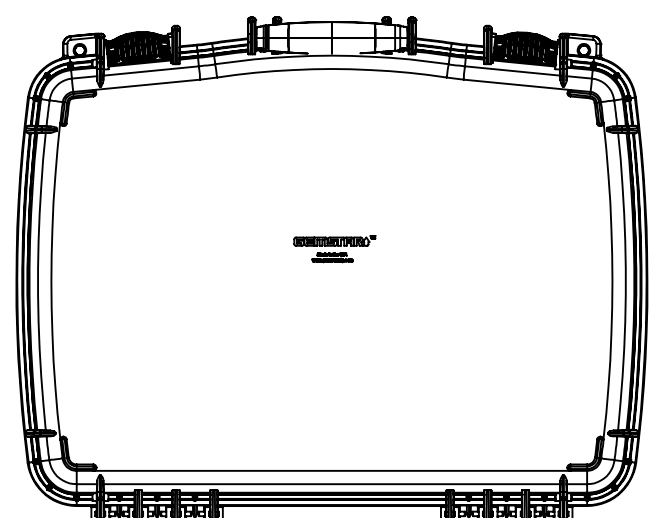

8 7 6 5 4 3 2 1

NOTE:
DIMENSIONS X.X ARE EXTERIOR DIMENSIONS
DIMENSIONS (X.X) ARE INTERIOR DIMENSIONS

SOURCE SUPPLIER Gemstar Manufacturing 103 Mensing Way Cannon Falls, MN 55009	CAGE CODE 36NE1	PROPRIETARY AND CONFIDENTIAL COMPUTER CONTROLLED DOCUMENT MANUAL ALTERATIONS PROHIBITED. INFORMATION CONTAINED IN THIS DRAWING ARE THE SOLE PROPERTY OF GEMSTAR MANUFACTURING. ANY REPRODUCTION IN PART OR AS A WHOLE WITHOUT THE WRITTEN PERMISSION OF GEMSTAR MANUFACTURING IS PROHIBITED.	UNLESS OTHERWISE SPECIFIED: DIMENSIONS ARE IN INCHES TOLERANCES MOLDED FEATURES +/- .030 + .005 IN/IN 5 AXIS MACHINED FEATURES FEATURE SIZE +/- .005 FEATURE TO FEATURE +/- 0.010 FIXTURE TO FEATURE +/- 0.031 HAND ROUTED FEATURE +/- .031		NAME	DATE	GEMSTAR MANUFACTURING		
			INTERPRET GEOMETRIC TOLERANCING PER: MATERIAL	DRAWN		TITLE: SENTINEL 1318-6			
DO NOT SCALE DRAWING			FINISH	ENG APPR.			SIZE B	DWG. NO.	REV
			COMMENTS:				SCALE: 1:6	WEIGHT:	SHEET 1 OF 1

A