



SENTINEL[®] Cases from Gemstar[®] are injection-molded cases engineered to deliver the ultimate protection for your most valuable assets—for sleek, lightweight protection that can stand up to any demand, choose SENTINEL.

Standard Features

- Injection molded construction
- Watertight, airtight, dustproof
- Automatic pressure relief valve
- Two molded-in padlock brackets
- EPDM gasket
- Military Grade Certification
- Stainless steel hardware
- Easy-open latches

Standard and Custom Options

- Offering a robust selection of custom features, colors, and sizes. For more information visit Gemstarmfg.com, or contact your local Distributor or Sales Manager.

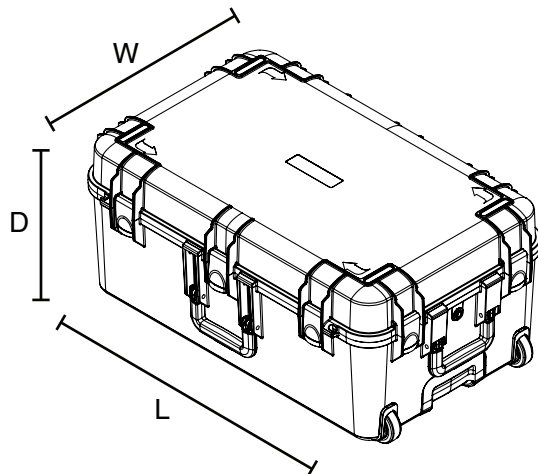

Nominal INT Dimension	29.7"L x 18.3"W x 12.3"D 754L x 465W x 312D mm
Base Depth	8.8" 224 mm
Lid Depth	3.5" 89 mm
Nominal EXT Dimension	31.9"L x 20.4"W x 14.0"D 810L x 518W x 356D mm
Approx. Weight	23.8 lbs 10.8 kg
Features	<ul style="list-style-type: none"> • Overmolded handle • Wheels • Pull handle • Easy-open latches (7)