



SENTINEL[®] Cases from Gemstar[®] are injection-molded cases engineered to deliver the ultimate protection for your most valuable assets—for sleek, lightweight protection that can stand up to any demand, choose SENTINEL.

Standard Features

- Injection molded construction
- Watertight, airtight, dustproof
- Automatic pressure relief valve
- Two molded-in padlock brackets
- EPDM gasket
- Military Grade Certification
- Stainless steel hardware
- Easy-open latches

Standard and Custom Options

• Offering a robust selection of custom features, colors, and sizes. For more information visit Gemstarmfg.com, or contact your local Distributor or Sales Manager.

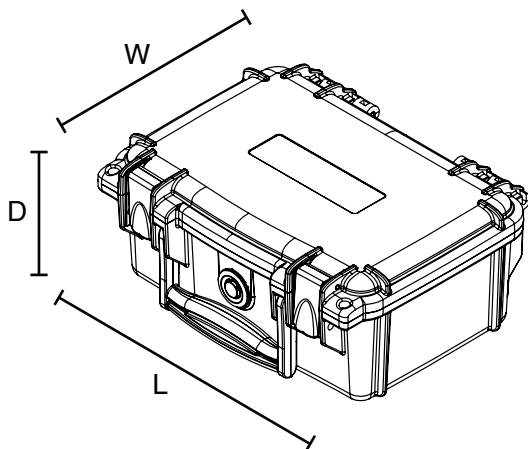

Nominal INT Dimension	7.7"L x 5.0"W x 3.3"D 196L x 127W x 84D mm
Base Depth	2.8" 71 mm
Lid Depth	0.5" 13 mm
Nominal EXT Dimension	8.7"L x 6.8"W x 3.8"D 221L x 173W x 97D mm
Approx. Weight	1.2 lbs 0.5 kg
Features	• Easy-open latches (2)