

8 7 6 5 4 3 2 1

D

D

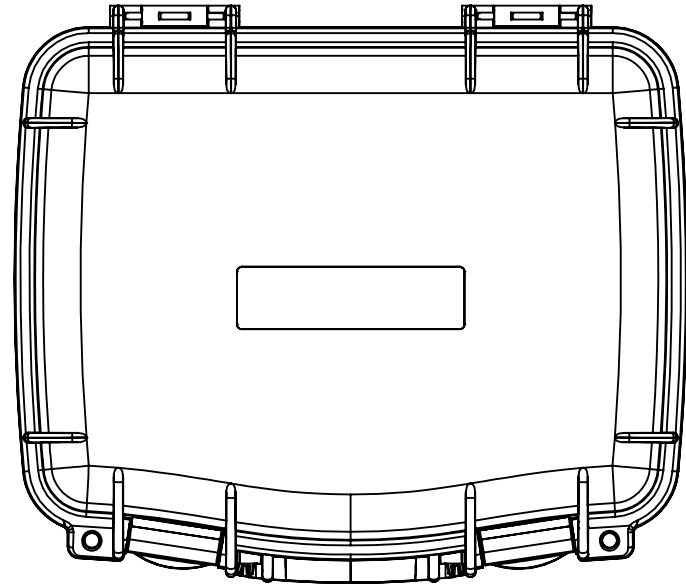

C

C

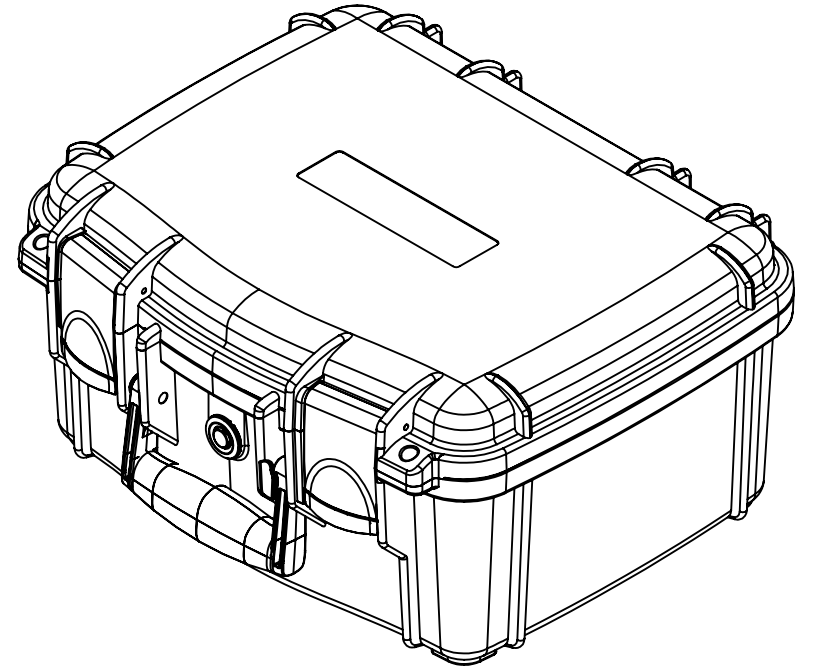

B

B

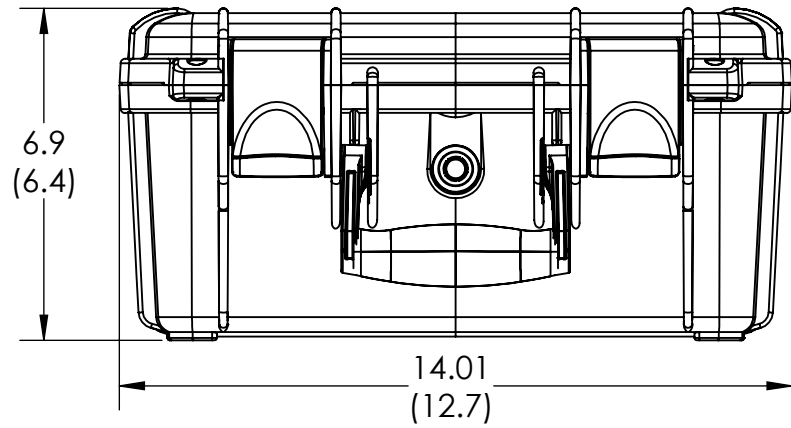

1.6
(1.3)

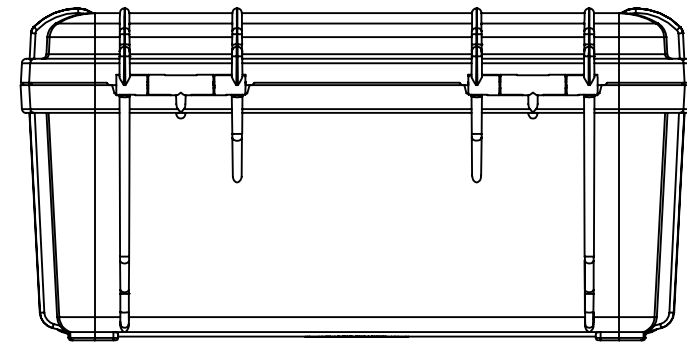
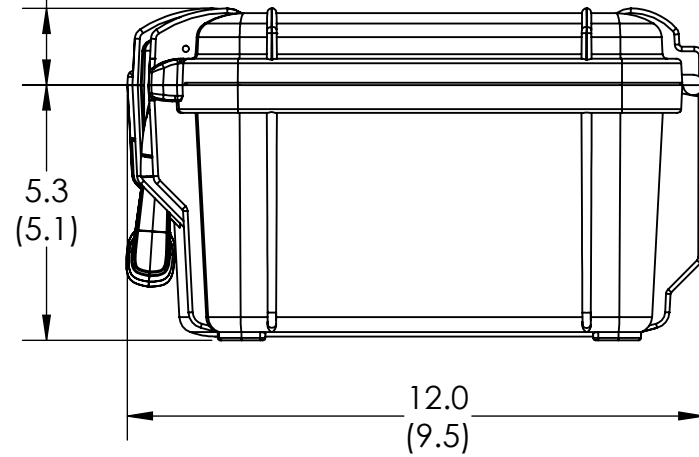

A

A

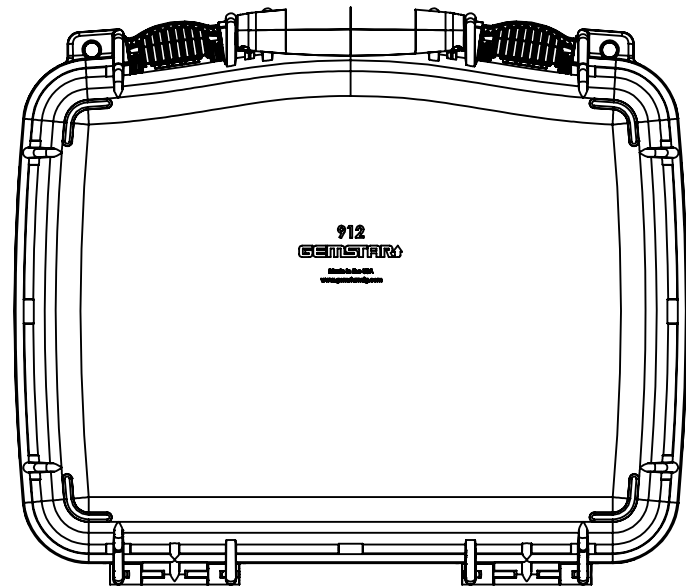

NOTE:
DIMENSIONS X.X ARE EXTERIOR DIMENSIONS
DIMENSIONS (X.X) ARE INTERIOR DIMENSIONS

SOURCE SUPPLIER Gemstar Manufacturing 103 Mensing Way Cannon Falls, MN 55009	UNLESS OTHERWISE SPECIFIED: DIMENSIONS ARE IN INCHES TOLERANCES MOLDED FEATURES +/- .030 + .005 IN/IN 5 AXIS MACHINED FEATURES FEATURE SIZE +/- .005 FEATURE TO FEATURE +/- 0.010 FIXTURE TO FEATURE +/- 0.031 HAND ROUTED FEATURE +/- .031	NAME	DATE	GEMSTAR MANUFACTURING TITLE: <h1>SENTINEL 912-6</h1>
		DRAWN CHECKED ENG APPR. MFG APPR.		
CAGE CODE <h2>36NE1</h2>	PROPRIETARY AND CONFIDENTIAL COMPUTER CONTROLLED DOCUMENT MANUAL ALTERATIONS PROHIBITED. INFORMATION CONTAINED IN THIS DRAWING ARE THE SOLE PROPERTY OF GEMSTAR MANUFACTURING. ANY REPRODUCTION IN PART OR AS A WHOLE WITHOUT THE WRITTEN PERMISSION OF GEMSTAR MANUFACTURING IS PROHIBITED.	Q.A. COMMENTS:	SCALE: 1:4	SHEET 1 OF 1
DO NOT SCALE DRAWING				

8 7 6 5 4 3 2 1