

8 7 6 5 4 3 2 1

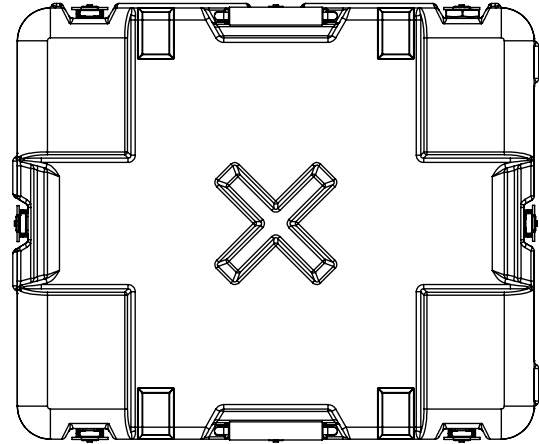
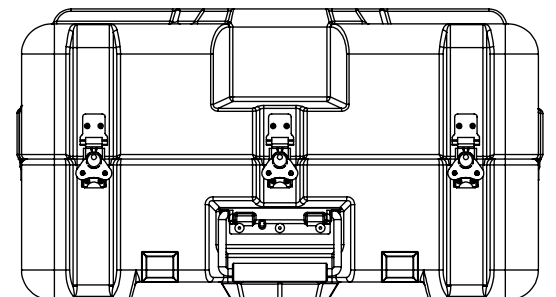
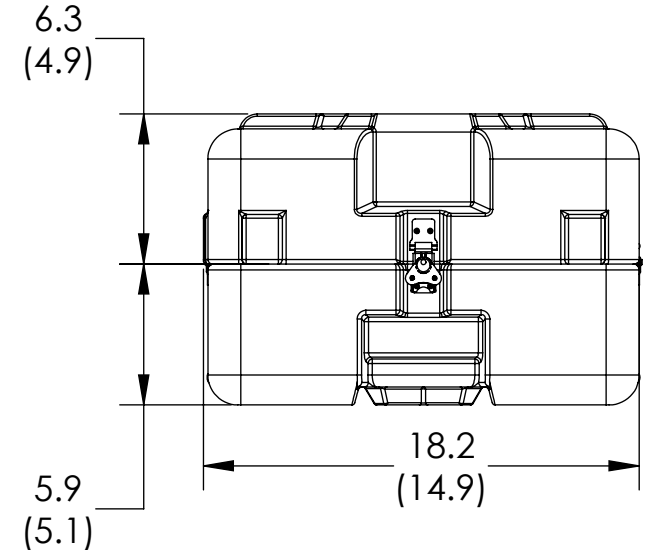
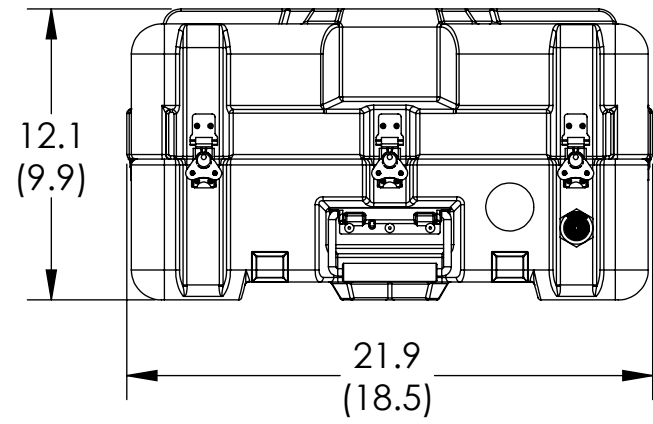
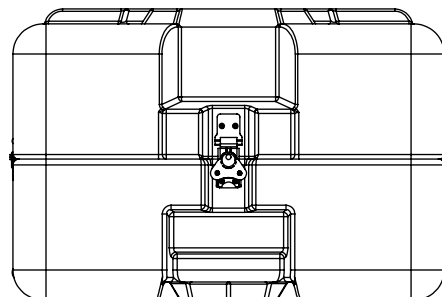
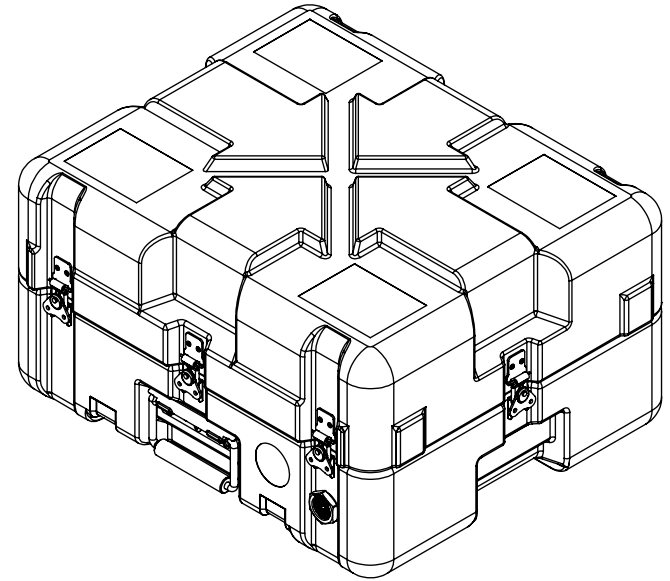
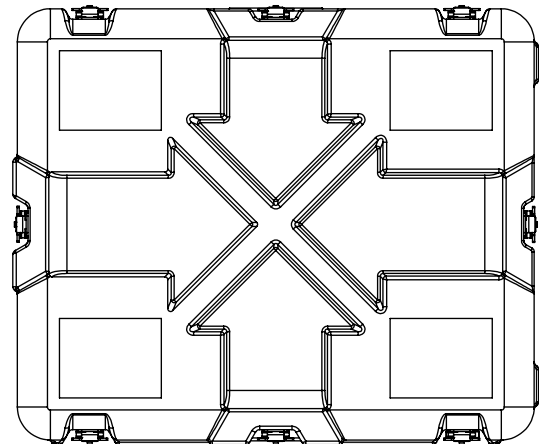

NOTE:
DIMENSIONS X.X ARE EXTERIOR DIMENSIONS
DIMENSIONS (X.X) ARE INTERIOR DIMENSIONS

SPECIALTY CASES
[DESIGN ■ SUPPORT ■ PROTECT]
P.O. Box 936
Sykesville, MD 21784
Phone: (800) 267-1674
<https://www.specialtycases.com>

SOURCE SUPPLIER
Gemstar Manufacturing
103 Mensing Way
Cannon Falls, MN 55009

CAGE CODE
36NE1

PROPRIETARY AND CONFIDENTIAL
THE INFORMATION CONTAINED IN THIS DRAWING IS THE SOLE PROPERTY OF GEMSTAR MANUFACTURING. ANY REPRODUCTION IN PART OR AS A WHOLE WITHOUT THE WRITTEN PERMISSION OF GEMSTAR MANUFACTURING IS PROHIBITED.

UNLESS OTHERWISE SPECIFIED:
DIMENSIONS ARE IN INCHES
TOLERANCES
MOLDED FEATURES +/- .030 + .005 IN/IN
5 AXIS MACHINED FEATURES
FEATURE SIZE +/- .005
FEATURE TO FEATURE +/- 0.010
FIXTURE TO FEATURE +/- 0.031
HAND ROUTED FEATURE +/- .031
INTERPRET GEOMETRIC TOLERANCING PER:
MATERIAL
FINISH
DO NOT SCALE DRAWING

NAME	DATE
DRAWN	
CHECKED	
ENG APPR.	
MFG APPR.	
Q.A.	
COMMENTS:	

GEMSTAR MANUFACTURING		
TITLE: SH1814-0504		
SIZE B	DWG. NO.	REV
SCALE: 1:8		SHEET 1 OF 1

8 7 6 5 4 3 2 1