

8 7 6 5 4 3 2 1

REVISIONS			
REV.	DESCRIPTION	DATE	APPROVED

D
C
B
A

D
C
B
A

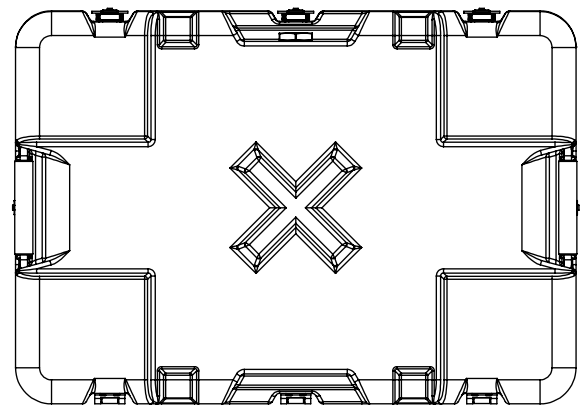
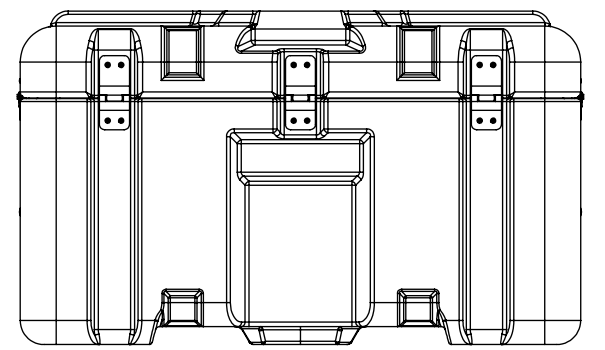
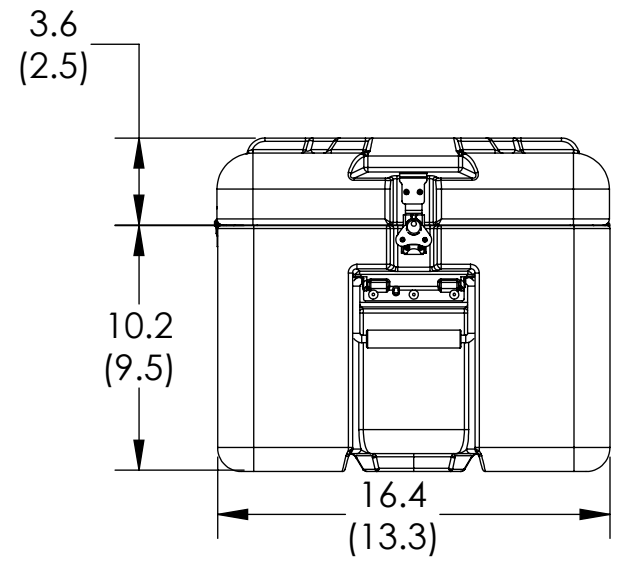
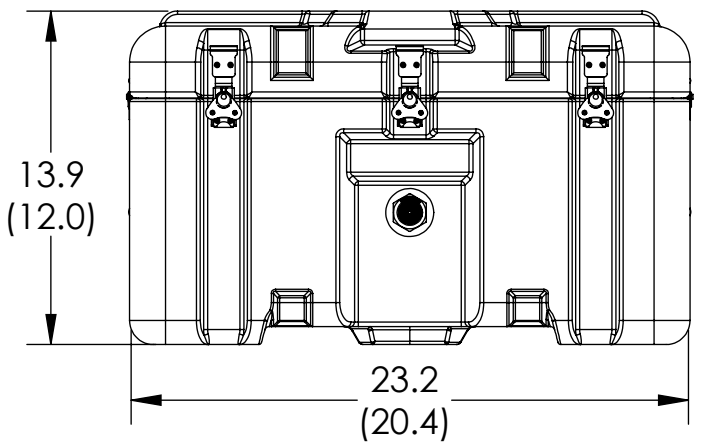
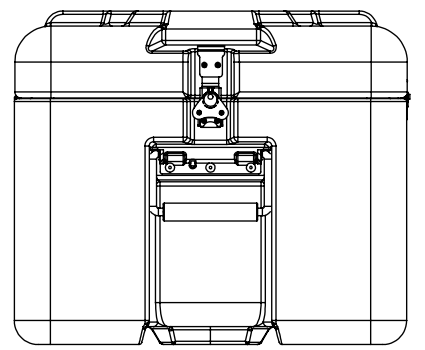
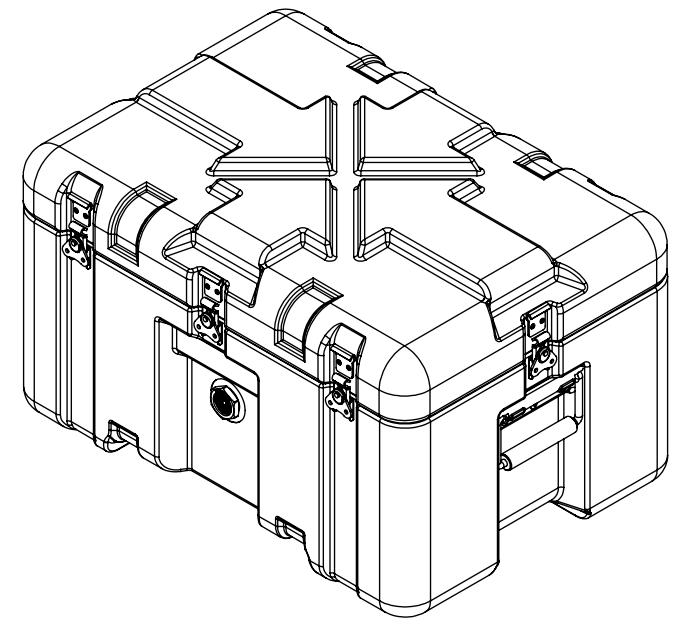
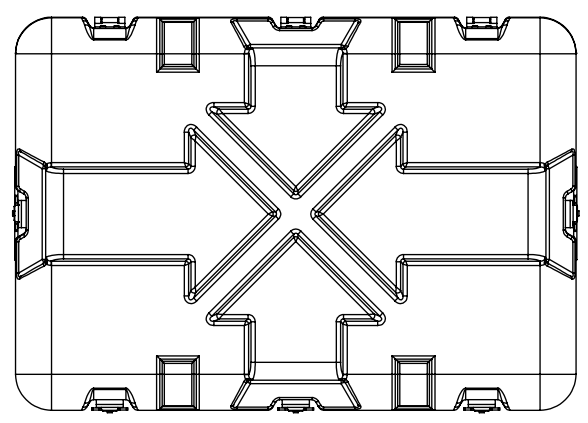

SPECIALTY CASES
 [DESIGN ■ SUPPORT ■ PROTECT]
 P.O. Box 936
 Sykesville, MD 21784
 Phone: (800) 267-1674
<https://www.specialtycases.com>

NOTE:
 DIMENSIONS X.X ARE EXTERIOR DIMENSIONS
 DIMENSIONS (X.X) ARE INTERIOR DIMENSIONS

UNLESS OTHERWISE SPECIFIED:
 DIMENSIONS ARE IN INCHES
 TOLERANCES
 MOLDED FEATURES +/- .030 + .005 IN/IN
 5 AXIS MACHINED FEATURES
 FEATURE SIZE +/- .005
 FEATURE TO FEATURE +/- 0.010
 FIXTURE TO FEATURE +/- 0.031
 HAND ROUTED FEATURE +/- .031

INTERPRET GEOMETRIC TOLERANCING PER:
 MATERIAL
 FINISH

DO NOT SCALE DRAWING

PROPRIETARY AND CONFIDENTIAL
 THE INFORMATION CONTAINED IN THIS DRAWING IS THE SOLE PROPERTY OF GEMSTAR MANUFACTURING. ANY REPRODUCTION IN PART OR AS A WHOLE WITHOUT THE WRITTEN PERMISSION OF GEMSTAR MANUFACTURING IS PROHIBITED.

NAME	DATE
DRAWN	
CHECKED	
ENG APPR.	
MFG APPR.	
Q.A.	
COMMENTS:	

GEMSTAR MANUFACTURING		
TITLE: SH2013-0902		
SIZE B	DWG. NO.	REV
SCALE: 1:8	SHEET 1 OF 1	

8 7 6 5 4 3 2 1