

8 7 6 5 4 3 2 1

D

C

B

A

D

C

B

A

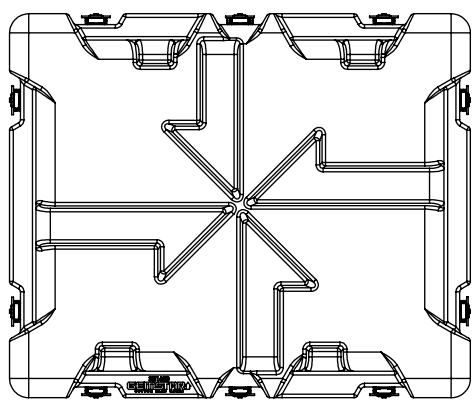
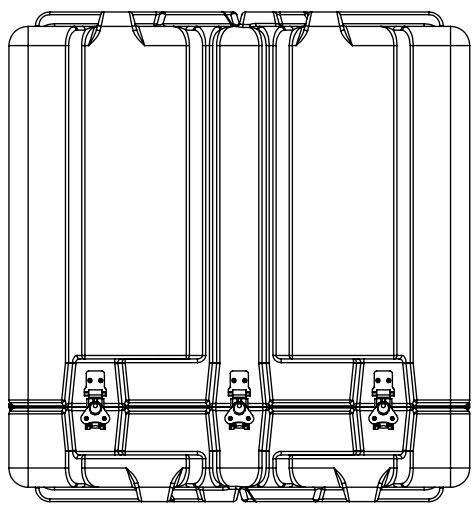
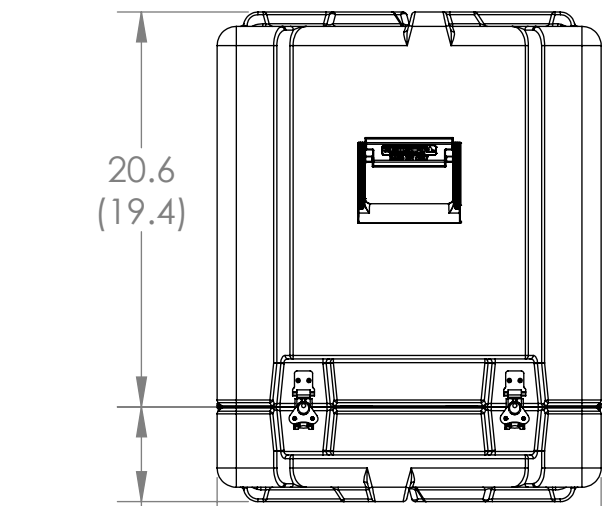
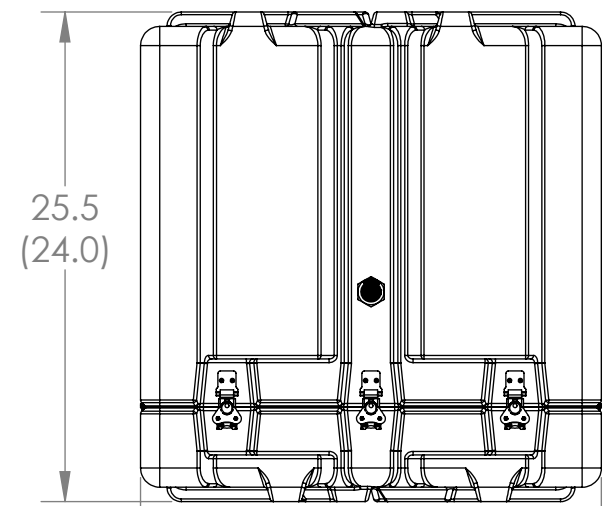
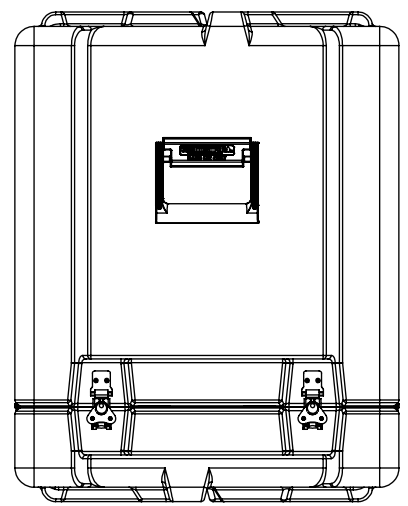
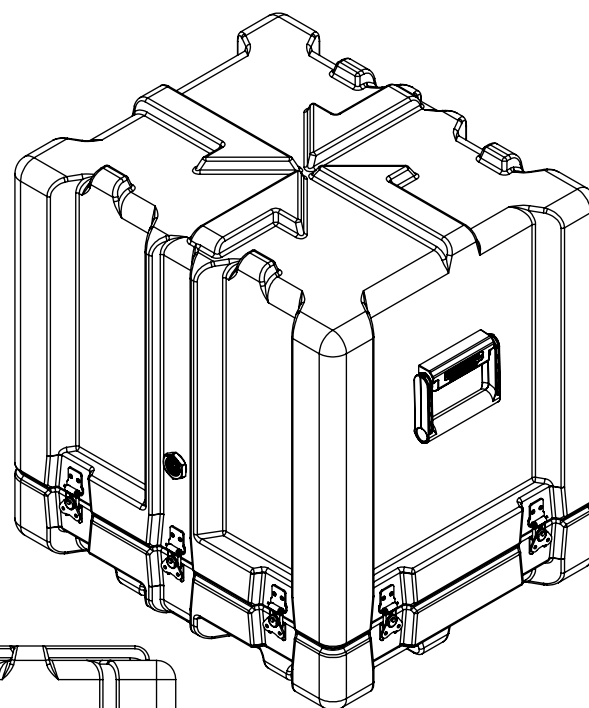
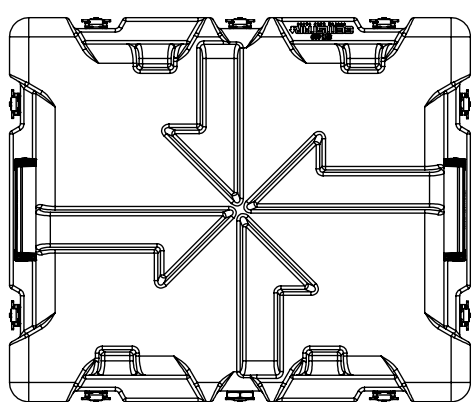

SPECIALTY CASES
 [DESIGN ■ SUPPORT ■ PROTECT]
 P.O. Box 936
 Sykesville, MD 21784
 Phone: (800) 267-1674
<https://www.specialtycases.com>

NOTE:
 DIMENSIONS X.X ARE EXTERIOR DIMENSIONS
 DIMENSIONS (X.X) ARE INTERIOR DIMENSIONS

SOURCE SUPPLIER Gemstar Manufacturing 103 Mensing Way Cannon Falls, MN 55009	CAGE CODE 36NE1	PROPRIETARY AND CONFIDENTIAL COMPUTER CONTROLLED DOCUMENT MANUAL ALTERATIONS PROHIBITED. INFORMATION CONTAINED IN THIS DRAWING ARE THE SOLE PROPERTY OF GEMSTAR MANUFACTURING. ANY REPRODUCTION IN PART OR AS A WHOLE WITHOUT THE WRITTEN PERMISSION OF GEMSTAR MANUFACTURING IS PROHIBITED.	UNLESS OTHERWISE SPECIFIED: DIMENSIONS ARE IN INCHES TOLERANCES MOLDED FEATURES +/- .030 + .005 IN/IN 5 AXIS MACHINED FEATURES FEATURE SIZE +/- .005 FEATURE TO FEATURE +/- 0.010 FIXTURE TO FEATURE +/- 0.031 HAND ROUTED FEATURE +/- .031	NAME DATE	GEMSTAR MANUFACTURING TITLE: SH2016-0419
			INTERPRET GEOMETRIC TOLERANCING PER: MATERIAL FINISH DO NOT SCALE DRAWING	COMMENTS: Q.A. MFG APPR. ENG APPR. CHECKED DRAWN	
			SCALE: 1:10		SHEET 1 OF 1

8 7 6 5 4 3 2 1