

4.9
(4.2)

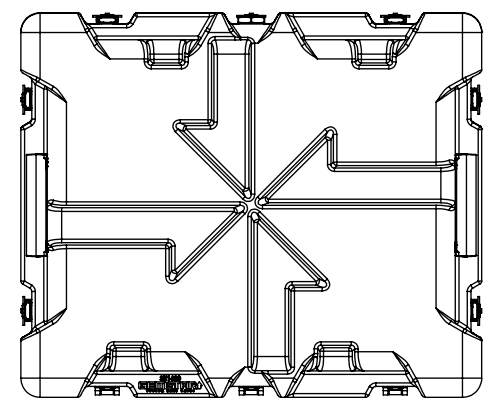
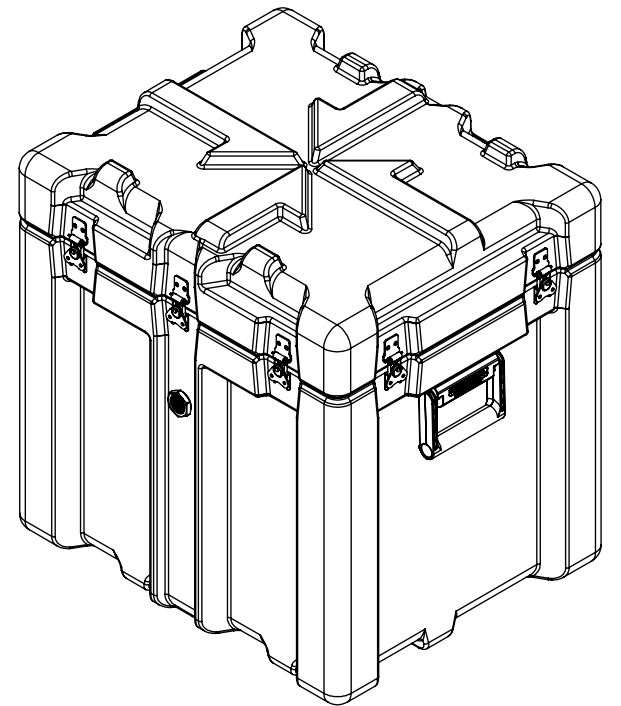
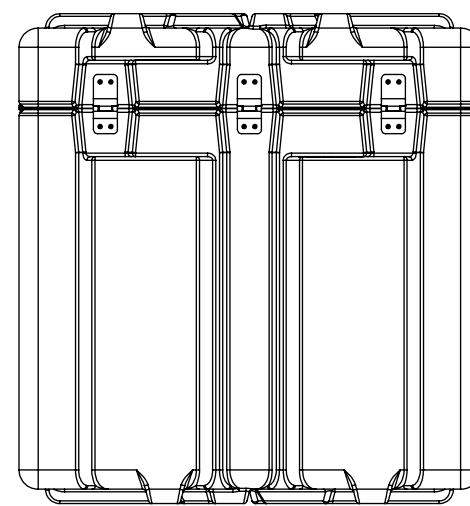
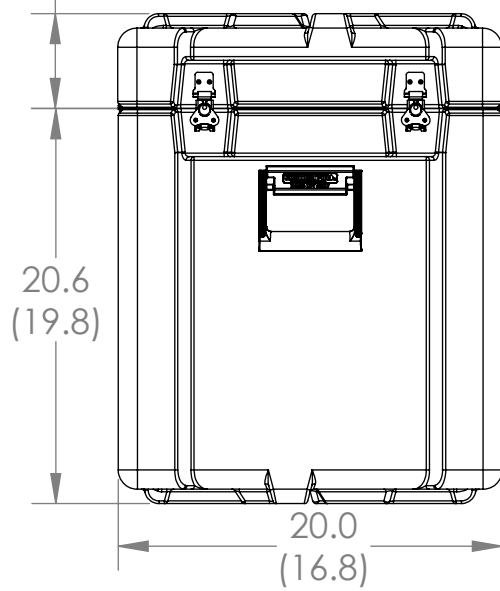

NOTE:
DIMENSIONS X.X ARE EXTERIOR DIMENSIONS
DIMENSIONS (X.X) ARE INTERIOR DIMENSIONS

SPECIALTY CASES

[DESIGN ■ SUPPORT ■ PROTECT]

P.O. Box 936
Sykesville, MD 21784
Phone: (800) 267-1674

<https://www.specialtycases.com>

SOURCE SUPPLIER Gemstar Manufacturing 103 Mensing Way Cannon Falls, MN 55009		UNLESS OTHERWISE SPECIFIED: DIMENSIONS ARE IN INCHES TOLERANCES MOLDED FEATURES +/- .030 + .005 IN/IN 5 AXIS MACHINED FEATURES FEATURE SIZE +/- .005 FEATURE TO FEATURE +/- 0.010 FIXTURE TO FEATURE +/- 0.031 HAND ROUTED FEATURE +/- .031		NAME	DATE	GEMSTAR MANUFACTURING	
CAGE CODE 36NE1		INTERPRET GEOMETRIC TOLERANCING PER: MATERIAL		DRAWN		TITLE: SH2016-1904	
PROPRIETARY AND CONFIDENTIAL COMPUTER CONTROLLED DOCUMENT MANUAL ALTERATIONS PROHIBITED. INFORMATION CONTAINED IN THIS DRAWING ARE THE SOLE PROPERTY OF GEMSTAR MANUFACTURING. ANY REPRODUCTION IN PART OR AS A WHOLE WITHOUT THE WRITTEN PERMISSION OF GEMSTAR MANUFACTURING IS PROHIBITED.		FINISH		CHECKED		SIZE DWG. NO. REV	
		DO NOT SCALE DRAWING		ENG APPR.		SCALE: 1:10 SHEET 1 OF 1	
				MFG APPR.			
				Q.A.			
				COMMENTS:			