



**GUARANTEED
PERFORMANCE**

STRONGHOLD[®] Cases from Gemstar[®] offer MIL-STD durability and airtight protection for high-value cargo. Featuring rotationally-molded double walls and thick corners STRONGHOLD is the choice for rugged, versatile and dependable protection.

Standard Features

- Rotationally molded, double-walled durability
- IP67 rated; watertight, airtight and dust-proof with automatic pressure relief valve
- Meets or exceeds MIL-STD 810F and meets military LLRC standards*
- Recessed, heavy-duty black stainless steel hardware
- Field serviceable hardware
- Spring-loaded handles
- Tongue & groove construction with gasket
- Interlocking, stackable design
- Choice of 10 standard colors
- Guaranteed Performance*

* See website for guarantee details, complete certifications and test procedures.

Standard Models

- SH2727-0909
- SH2727-0922
- SH2727-2309
- SH2727-2322

Standard and Custom Options

• Offering a robust selection of custom features, colors, and sizes. For more information visit **Gemstarmfg.com**, or contact your local Distributor or Sales Manager.

Standard Color Options**



** Colors are approximate and are for visual purposes only.

SH2727-0909 Top Profile

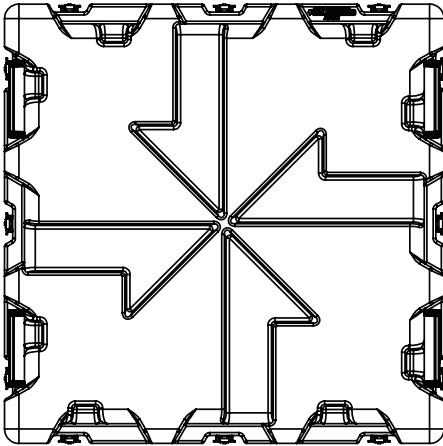

MODEL NUMBER KEY

SH27 27-09 09

Length ———— Lid
Width ———— Base
Model numbers refer to interior dimensions

SH2727-0909 Side and End Profile

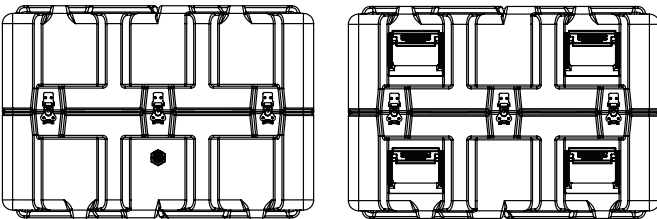

Nominal INT Dimension	27.0"L x 27.0"W x 18.9"D 686L x 686W x 480D mm
Base Depth	9.6" 244 mm
Lid Depth	9.3" 236 mm
Nominal EXT Dimension	30.5"L x 30.5"W x 20.8"D 775L x 775W x 528D mm
Approx. Weight	37.5 lbs 17.0 kg
Features	<ul style="list-style-type: none"> • Removable lid • Textured plastic handles (4) • PRV

SH2727-0922 Top Profile

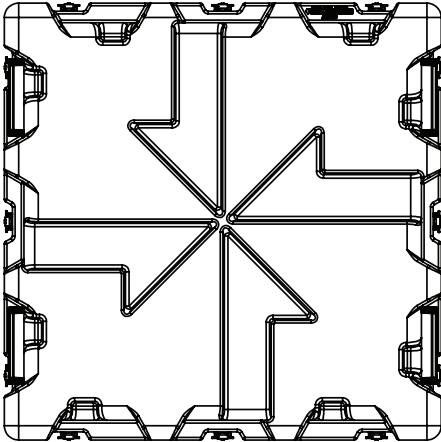

MODEL NUMBER KEY

SH27 27-09 22

Length ———— Lid
Width ———— Base
Model numbers refer to interior dimensions

SH2727-0922 Side and End Profile

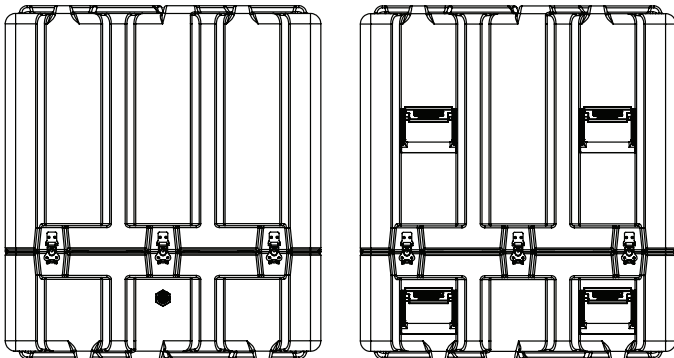

Nominal INT Dimension	27.0"L x 27.0"W x 32.2"D 686L x 686W x 818D mm
Base Depth	9.6" 244 mm
Lid Depth	22.6" 574 mm
Nominal EXT Dimension	30.5"L x 30.5"W x 34.2"D 775L x 775W x 869D mm
Approx. Weight	50.0 lbs 22.7 kg
Features	<ul style="list-style-type: none"> • Removable lid • Textured plastic handles (8) • PRV

SH2727-2309 Top Profile

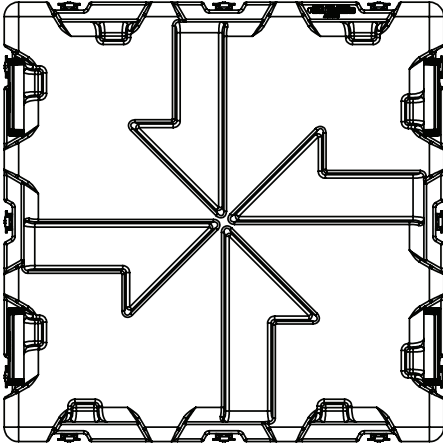

MODEL NUMBER KEY

SH27 27-23 09

Length ———— Lid
Width ———— Base
Model numbers refer to interior dimensions

SH2727-2309 Side and End Profile

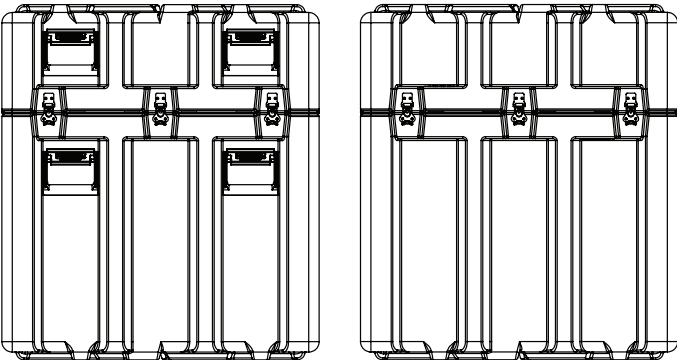

Nominal INT Dimension	27.0"L x 27.0"W x 32.3"D 686L x 686W x 820D mm
Base Depth	23.8" 605 mm
Lid Depth	9.3" 236 mm
Nominal EXT Dimension	30.5"L x 30.5"W x 34.1"D 775L x 775W x 866D mm
Approx. Weight	50.0 lbs 22.7 kg
Features	<ul style="list-style-type: none"> • Removable lid • Textured plastic handles (8) • PRV

SH2727-2322 Top Profile

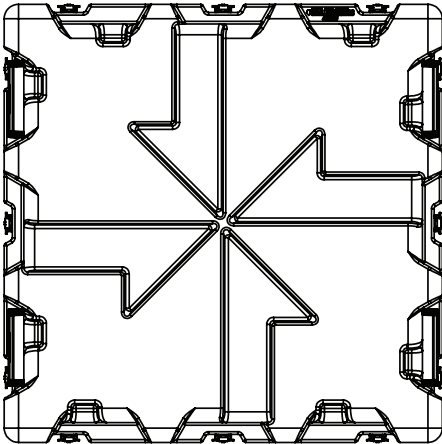

MODEL NUMBER KEY

SH27 27-23 22

Length ———— Lid
Width ———— Base
Model numbers refer to interior dimensions

SH2727-2322 Side and End Profile

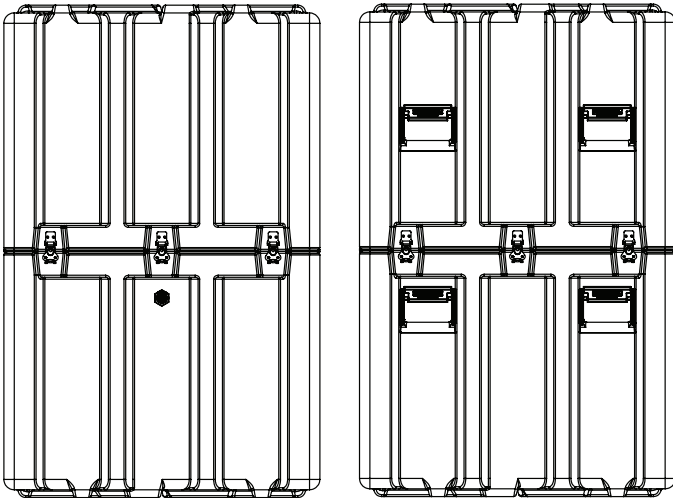

Nominal INT Dimension	27.0"L x 27.0"W x 45.6"D 686L x 686W x 1,158D mm
Base Depth	23.0" 584 mm
Lid Depth	22.6" 574 mm
Nominal EXT Dimension	30.5"L x 30.5"W x 47.5"D 775L x 775W x 1,207D mm
Approx. Weight	61.5 lbs 27.9 kg
Features	<ul style="list-style-type: none"> • Removable lid • Textured plastic handles (8) • PRV