

8 7 6 5 4 3 2 1

D  
C  
B  
A

D  
C  
B  
A

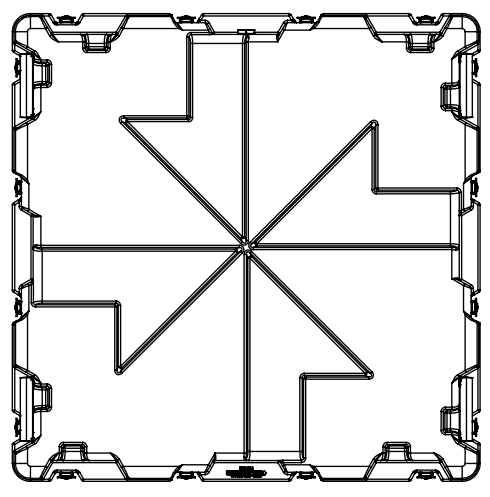
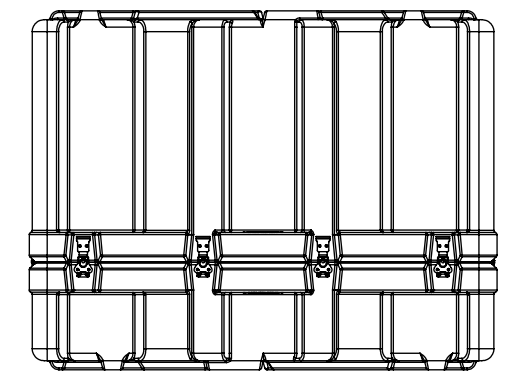
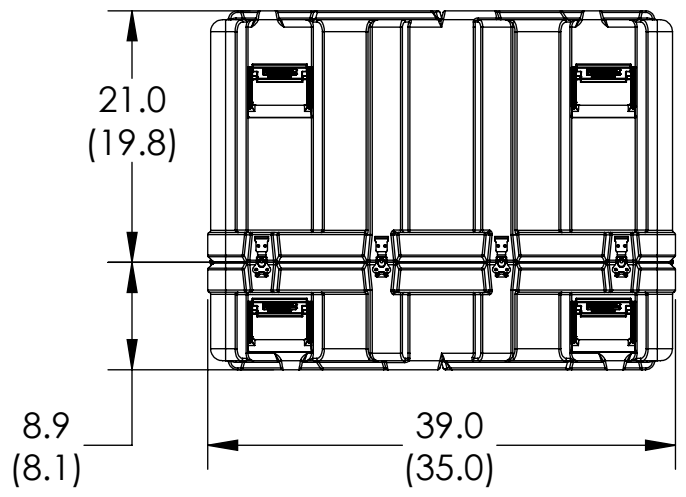
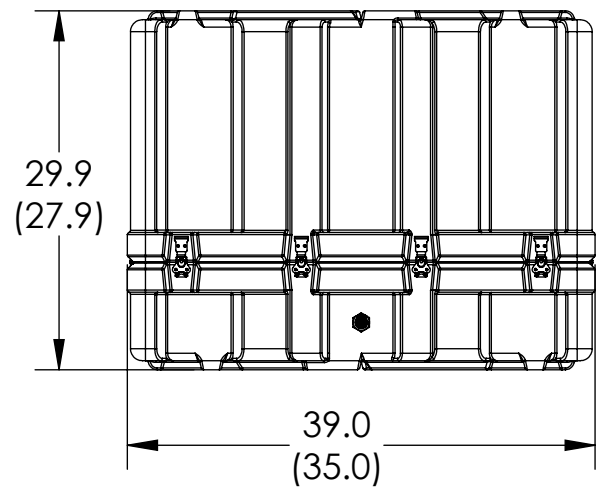
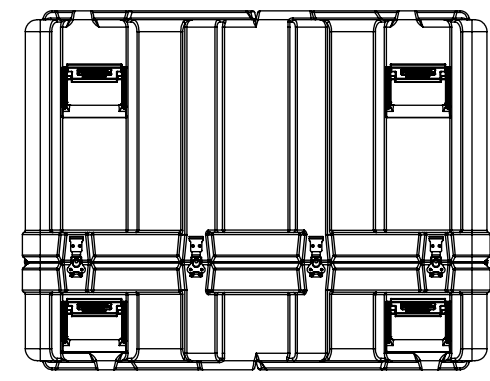
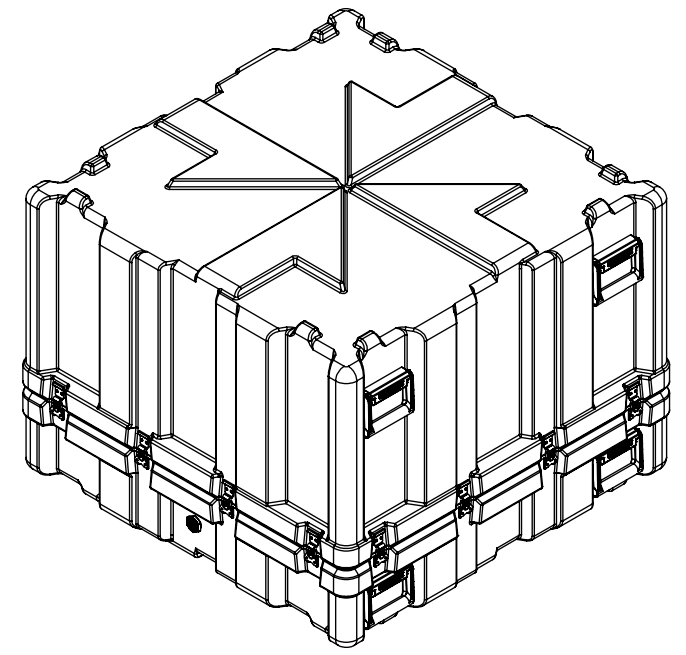
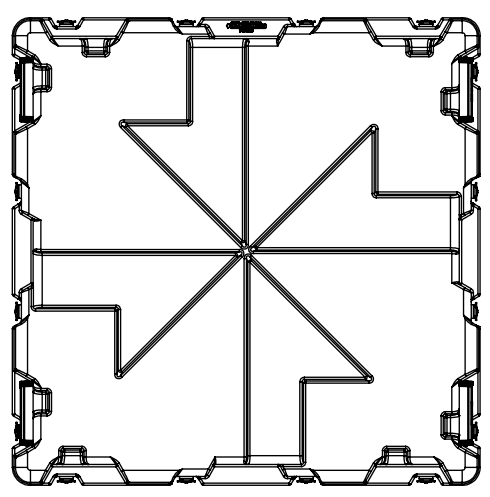

NOTE:  
DIMENSIONS X.X ARE EXTERIOR DIMENSIONS  
DIMENSIONS (X.X) ARE INTERIOR DIMENSIONS

**SPECIALTY CASES**  
[DESIGN ■ SUPPORT ■ PROTECT]  
P.O. Box 936  
Sykesville, MD 21784  
Phone: (800) 267-1674  
<https://www.specialtycases.com>

<b>SOURCE SUPPLIER</b> Gemstar Manufacturing 103 Mensing Way Cannon Falls, MN 55009  <b>CAGE CODE</b> <b>36NE1</b>  <b>PROPRIETARY AND CONFIDENTIAL</b> THE INFORMATION CONTAINED IN THIS DRAWING IS THE SOLE PROPERTY OF GEMSTAR MANUFACTURING. ANY REPRODUCTION IN PART OR AS A WHOLE WITHOUT THE WRITTEN PERMISSION OF GEMSTAR MANUFACTURING IS PROHIBITED.	UNLESS OTHERWISE SPECIFIED: DIMENSIONS ARE IN INCHES TOLERANCES MOLDED FEATURES +/- .030 + .005 IN/IN 5 AXIS MACHINED FEATURES FEATURE SIZE +/- .005 FEATURE TO FEATURE +/- 0.010 FIXTURE TO FEATURE +/- 0.031 HAND ROUTED FEATURE +/- .031  INTERPRET GEOMETRIC TOLERANCING PER: MATERIAL  FINISH  DO NOT SCALE DRAWING	NAME	DATE	<b>GEMSTAR MANUFACTURING</b>  TITLE: <h1>SH3535-0819</h1>
		DRAWN CHECKED ENG APPR. MFG APPR. Q.A. COMMENTS:		
		SIZE	DWG. NO.	REV
		<b>B</b>		
		SCALE: 1:16	SHEET 1 OF 1	

8 7 6 5 4 3 2 1