

NANUK™



996

NEW NOUVEAU

3 POSSIBLE CONFIGURATIONS
CONFIGURATIONS POSSIBLES



LIFETIME WARRANTY
GARANTIE À VIE



IP67 WATERPROOF
ÉTANCHE À L'EAU IP67



MADE IN CANADA
FABRIQUÉ AU CANADA



MILITARY APPROVED
CERTIFIÉ MILITAIRE



CRUSHPROOF RESIN
RÉSINE INÉCRASABLE

At more than 58" or 148cm, the NANUK 996 is our longest long case we've ever made. Built for extra long equipment that requires premium protection that's waterproof and dustproof. Available empty or with 4 solid foam layers interior, this case is long on options.

The NANUK 996 was built to organize, protect, and mobilize industrial equipment to photography lighting equipment to long firearms to musical instruments, and much more. The 996 is strong, tough, and virtually indestructible thanks to its NK-7 resin shell and ultra tough wheels, handles, and legendary PowerClaw latches.

Avec plus de 58" ou 148 cm, la NANUK 996 est la valise la plus longue que nous ayons jamais fabriqué. Conçu pour les équipements extra longs nécessitant une protection haut de gamme, à la fois étanche et antipoussière. Disponible vide ou avec un intérieur en mousse solide de 4 couches, cette valise offre de nombreuses options.

La NANUK 996 a été conçue pour organiser, protéger et transporter des équipements industriels, des équipements d'éclairage photographique, des armes à feu longues, des instruments de musique et bien plus encore. La 996 est solide, robuste et pratiquement indestructible grâce à sa coque en résine NK-7 et à ses roues ultra résistantes, ses poignées, et ses légendaires loquets PowerClaw.

SPECIFICATIONS | SPÉCIFICATIONS

Interior dimensions <i>Dimensions intérieures</i>	L55.12" x W16.12" x H8.93" L1400mm x W409mm x H226mm
Exterior dimensions <i>Dimensions extérieures</i>	L58.37" x W18.87" x H10" L1482mm x W479mm x H254mm
Weight <i>Poids</i>	12.7 kg 28.0 lbs
Lid depth <i>Profondeur du couvercle</i>	2.18" 55mm
Base depth <i>Profondeur de la base</i>	6.75" 171mm
Max buoyancy <i>Flottabilité maximum</i>	N/A
Temperature range <i>Plage de températures</i>	Min -20°F (-29°C) Max 140°F (60°C)
Airline cabin carry-on <i>Bagage de cabine</i>	No Non
Watertight <i>Étanche</i>	Yes - IP67 <i>Oui - IP67</i>
Warranty <i>Garantie</i>	Conditional lifetime guarantee <i>Garantie à vie conditionnelle</i>

ACCESSORIES | ACCESSOIRES



Set of 2 bottom corner caps
Ensemble de deux coins



Multilayer Solid Foam
Mousse en cube multicouches



ID Window
Plaque ID



TSA Approved Padlock
Cadenas TSA



Panel Installation Kit
Kit d'installation pour panneau



TSA Approved Latches
Fermeurs à serrures TSA



3 POSSIBLE CONFIGURATIONS CONFIGURATIONS POSSIBLES

If your needs change, the wheel rigs on the 996 are removable and can be replaced by our custom corner caps.

Si vos besoins changent, les supports de roue du 996 sont amovibles et peuvent être remplacés par nos capuchons de coin personnalisés.



996

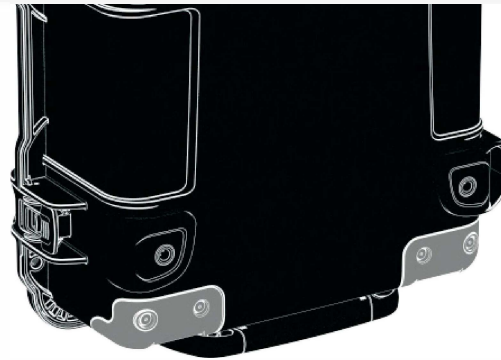

996T



996M

*Custom Order.
MOQ Applies

*Commande spéciale.
Quantité minimum
requis

FEATURES | CARACTÉRISTIQUES

3 soft grip strong handles
3 poignées solides à prise souple

2 large and strong polyurethane wheels
2 roues larges et solides en polyuréthane

2 automatic pressure equalization valves
2 valves d'équilibrage automatique de la pression

Lower corner caps
Capuchons d'angle inférieur

Stackable
Empilable

996

996T

996M



CERTIFICATIONS | CERTIFICATIONS



DEF-STAN 81-41
DEF-STAN 81-41



IP6X Ingress protection dustproof
IP6X Indice de protection anti-poussière



IP7X Ingress protection Waterproof
IP7X Indice de protection étanche à l'eau



ASTM D-4169 DC-18 Drop Test
ASTM D-4169 DC-18 Test de chute



Mil-STD-810F Immersion
Mil-STD-810F Test d'immersion



MIL-STD-810G - Fungus Test
MIL-STD-810G - Test fongique



ATA Specification 300 Category 1 Impact
Spécification ATA 300 - Catégorie 1 test d'impact

MATERIALS | MATÉRIAUX

Case Shell – NK-7 High Impact Polypropylene
Coquille de la mallette - NK-7 Polypropylène résistant aux chocs

Latches – Nylon 66
Fermeurs - Nylon 66

Handle – NK-7 High Impact Polypropylene | TPE
Poignée - NK-7 Polypropylène résistant aux chocs | TPE

Purge Valve – Nylon 66 | Gore Membrane | Silicone Washers
Valve d'équilibrage - Nylon 66 | Membrane Gore® | Rondelles en silicone

Pins/Hardware – 304 Stainless Steel
Tiges/quincaillerie - Acier inoxydable 304

Gasket – EPDM
Joint d'étanchéité - EPDM

Wheels – Polyurethane | Polycarbonate
Roues - Polyuréthane | Polycarbonate



North America Headquarters

Plasticase Inc.
1059 Boulevard des Entreprises Ouest
Terrebonne, Québec, Canada J6Y 1V2

T: 450.628.1006 | 1.800.783.6883
E: info@nanuk.com
www.nanukcases.ca

Plasticase USA Inc./NANUK

2915 Ogletown Road
Newark, Delaware,
19713 USA

T: 450.628.1006 | 1.800.783.6883
E: info@nanuk.com
www.nanuk.com

NANUK EU B.V. NANUK Europe

Burg. J.G. Legroweg 96
9761TD Eelde,
The Netherlands

T: +31 50 3128694
E: info@nanuk.eu
www.nanuk.eu

NANUK™



LIFETIME
WARRANTY



MILITARY
APPROVED

996 FEATURES CARACTÉRISTIQUES



2 Large and Strong Polyurethane Wheels
2 grandes et solides roues en polyuréthane



Highly Stackable
Hautement empilable



8x M8 Threaded Steel Inserts
8x inserts filetés en acier M8



6x Powerclaw Latches
6x loquets Powerclaw

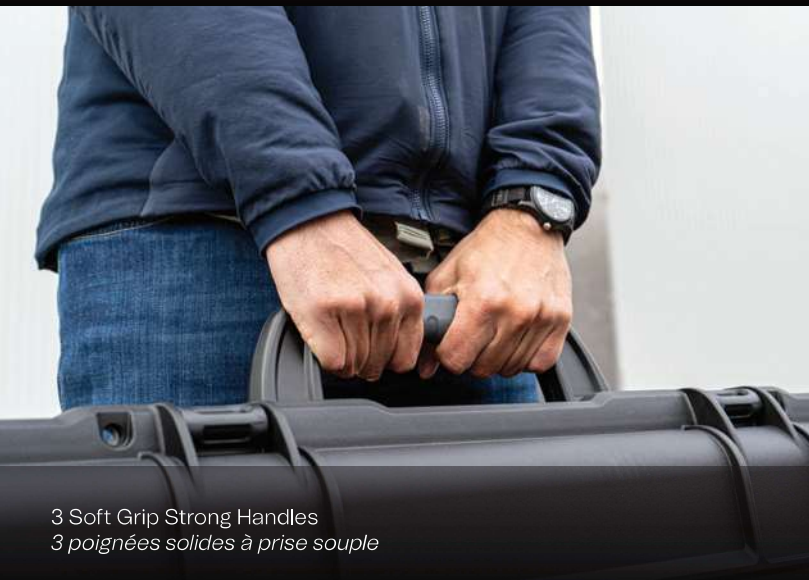

3 Soft Grip Strong Handles
3 poignées solides à prise souple



ID Window Compatible (Optional)
Compatible avec fenêtre d'identification (en option)